

# ***Mechanical Fatigue and Load-Induced Aging of Loudspeaker Suspension***

Wolfgang Klippel,

Institute of Acoustics and Speech Communication  
Dresden University of Technology

presented at the ALMA Symposium 2012, Las Vegas

# Abstract

The mechanical suspension becomes more and more compliant over time changing the loudspeaker properties (e.g. resonance frequency) significantly. This aging process is reproducible and the decay of the stiffness can be modeled by accumulating the apparent power supplied to the suspension part and using an exponential relationship. The free parameters of this model are estimated from empirical data provided by on-line monitoring or intermittent measurements during regular power tests or other kinds of long-term testing. The identified model can be used to predict the load-induced aging for music or test signals having arbitrary spectral properties. New characteristics are being introduced which simplify the quality assessment of suspension parts and separate mechanical fatigue from the initial break-in effect. Practical experiments are performed to verify the model and to demonstrate the diagnostic value for selecting optimal suspension parts providing sufficient long-term stability.

# Questions addressed in the paper



- Why is the suspension the weakest loudspeaker part ?
- How to measure the long-term stability of soft parts ?
- How to consider the influence of the mechanical load on the aging ?
- How to separate the early break-in process from fatigue ?
- How to predict the final loss of stiffness ?
- How to design and select good suspension parts ?

# Road Map

- Introduction (problem, history)
- Modeling of load-induced aging
- Measurement techniques
- Practical application (diagnostics)
- Conclusion

# Variation of Suspension Stiffness $K(t)$ versus Measurement Time $t$

Performing a power test with pink noise of constant amplitude

Stiffness ratio after 1 h and 100 h power testing

$$R_{100h} = \frac{K(t = 100h)}{K(t = 1h)}$$

Disadvantages of :

- measurement results depends on the properties of the stimulus
- assumes constant excitation during power test
- can not be transferred to other stimuli
- neglects the slope of the stiffness variation

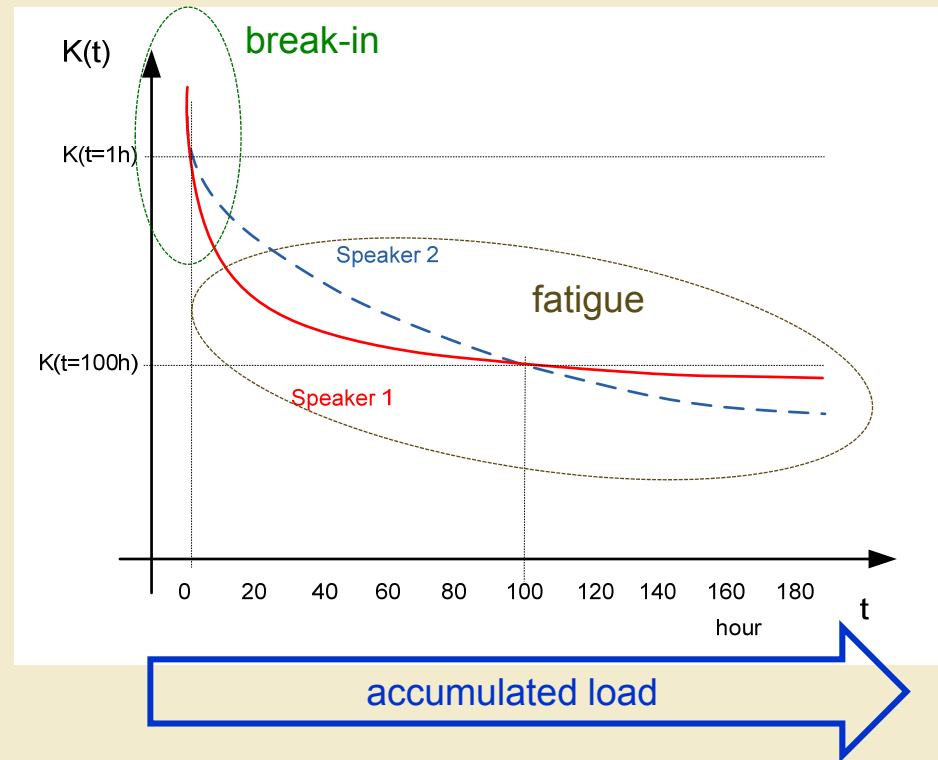

*Idea:  
Replacing time  $t$  by a quantity  
describing the dosage of the  
mechanical load*

# Conventional Measurement of Fatigue

*S-N Curves (Wöhler) show the sinusoidal stress  $S$  and number of cycles  $N$  causing a failure*

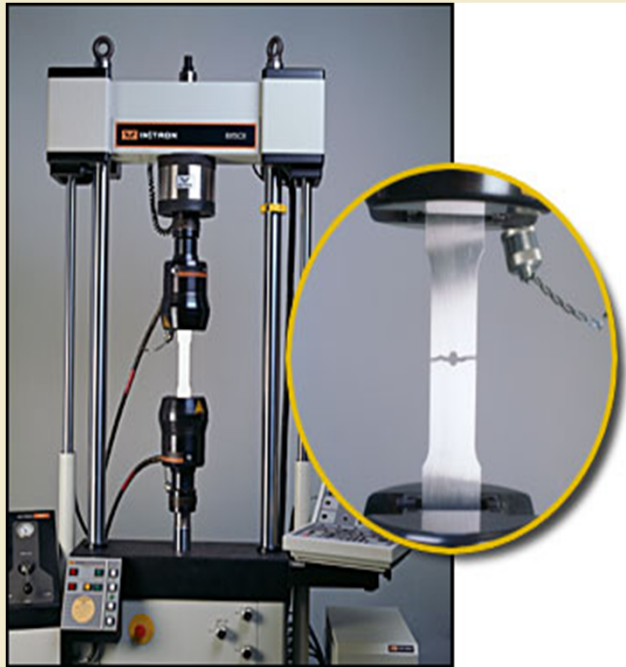

*Courtesy by Coldwork.com*

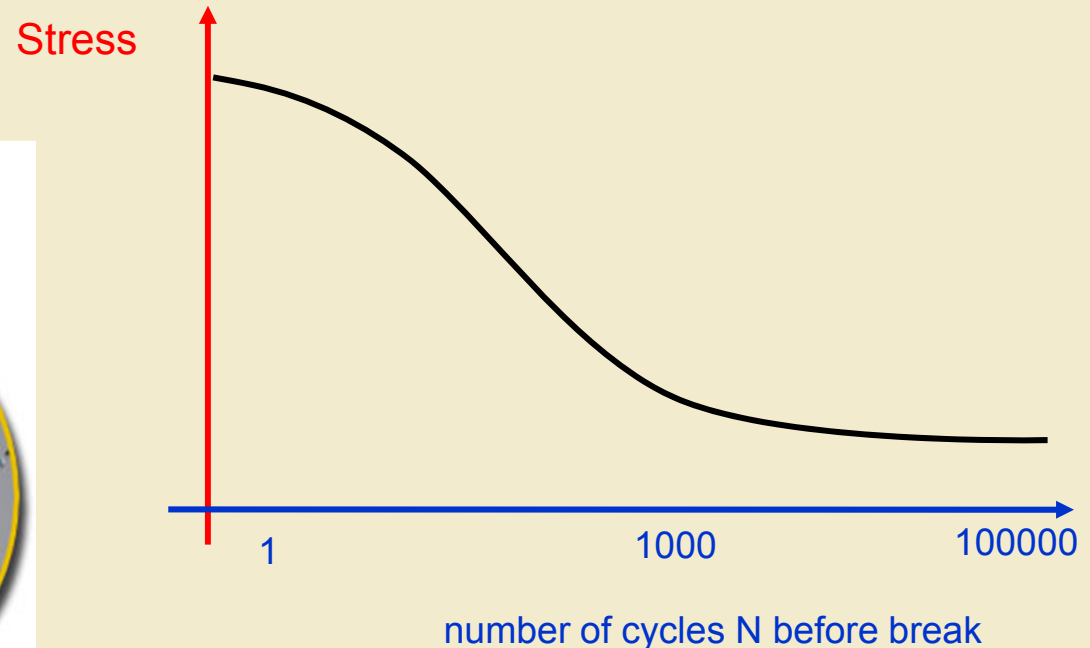

→ cannot be directly applied to loudspeaker suspensions because we are interested in the stiffness variation before a fatal break occurs

# Loudspeaker Suspension

The load-induced variation of the stiffness depends on

- the potential energy temporarily stored in the suspension considering the nonlinear force-deflection characteristic,
- energy dissipated into heat by losses in the material,
- frequency (cycles) of an alternating stimulus,
- accumulated power transferred to the suspension part during life time of the suspension,
- other unknown factors ...

# How to define the Mechanical Load ?

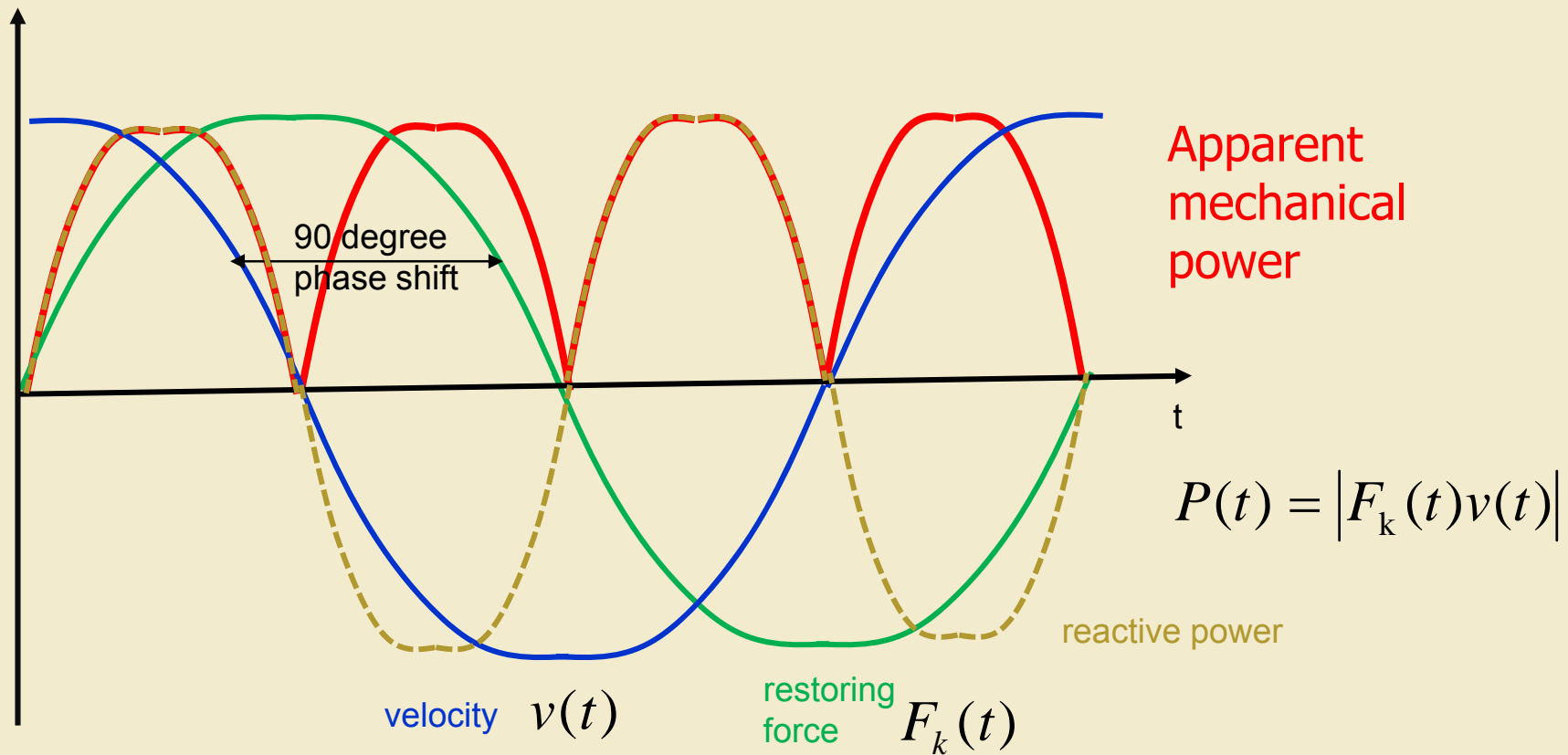

Apparent mechanical work performed on the suspension over life time

$$W(t_m) = \int_0^{t_m} P(t)dt = \bar{P}t_m.$$

# Constant Load Model

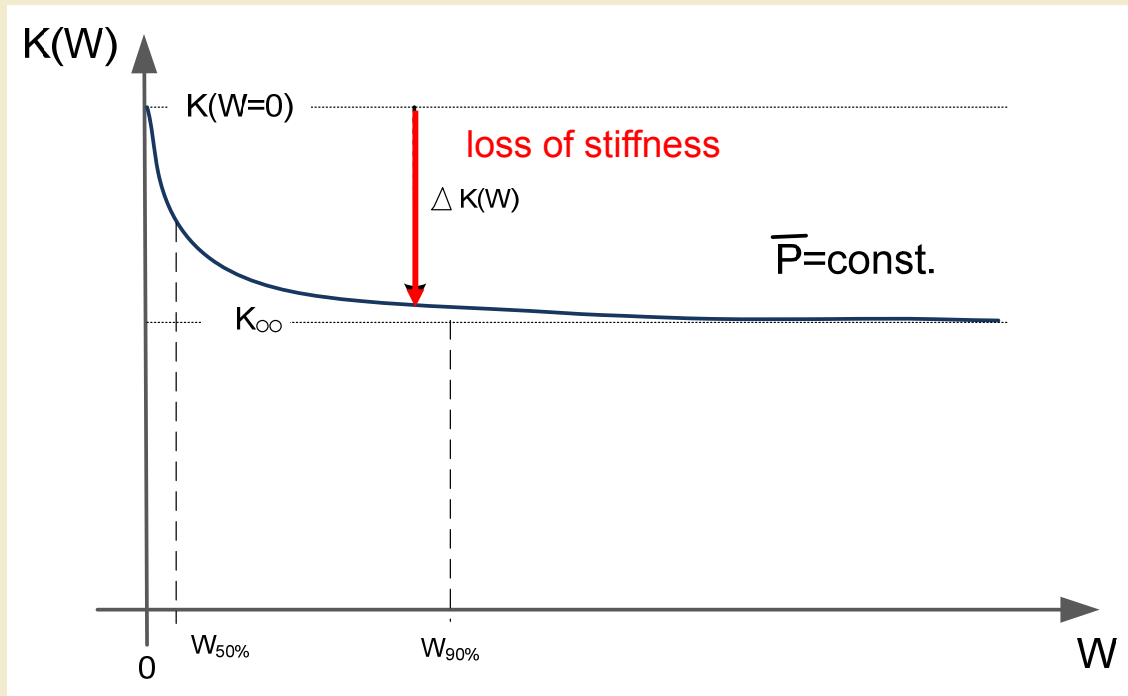

Measurement  
Condition:  
same stimulus of  
constant amplitude  
during the power  
test

Stiffness of loudspeaker suspension versus  
accumulated work  $W$

$$\hat{K}(W) = K(W=0) - \Delta K(W)$$

$$\Delta K(W) = \sum_{i=1}^N C_i \left(1 - e^{-W/w_i}\right)$$

$N=2$  sufficient for most cases

# 1<sup>st</sup> Characteristic: Relative Aging Ratio

Definition:

$$a(W) = \frac{K(W=0) - K(W)}{\sum_{i=1}^N C_i} 100 \%$$

- describes the progress of the ageing process in percent
- approaches 100 % for infinite work

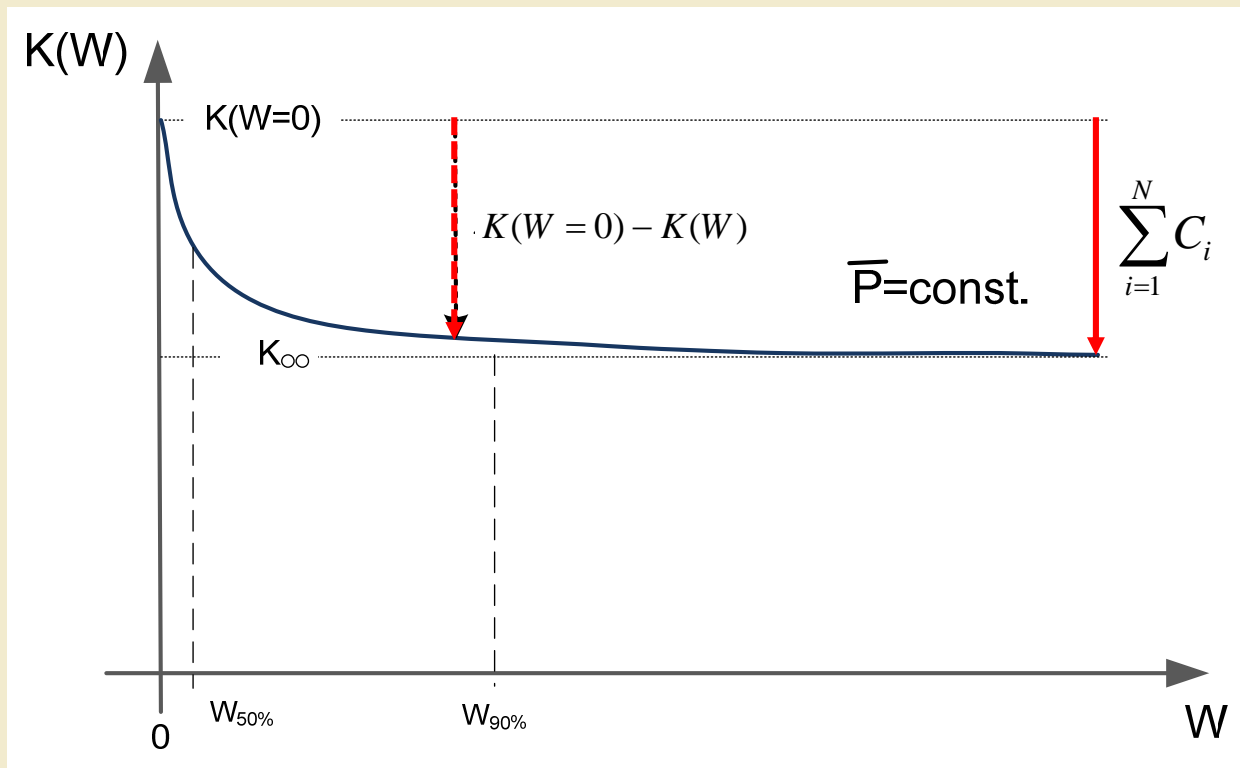

Derived Characteristics:

final value of stiffness

$$\hat{K}(W \rightarrow \infty) = \hat{K}_{\infty} = K(0) - \sum_{i=1}^N C_i$$

Total loss of stiffness during life time

$$V_a = \frac{\sum_{i=1}^N C_i}{K(W=0)} 100\%$$

$$a(W_{50\%}) = 50\%$$

$$a(W_{90\%}) = 90\%$$

## 2<sup>nd</sup> Characteristic: Break-in Ratio

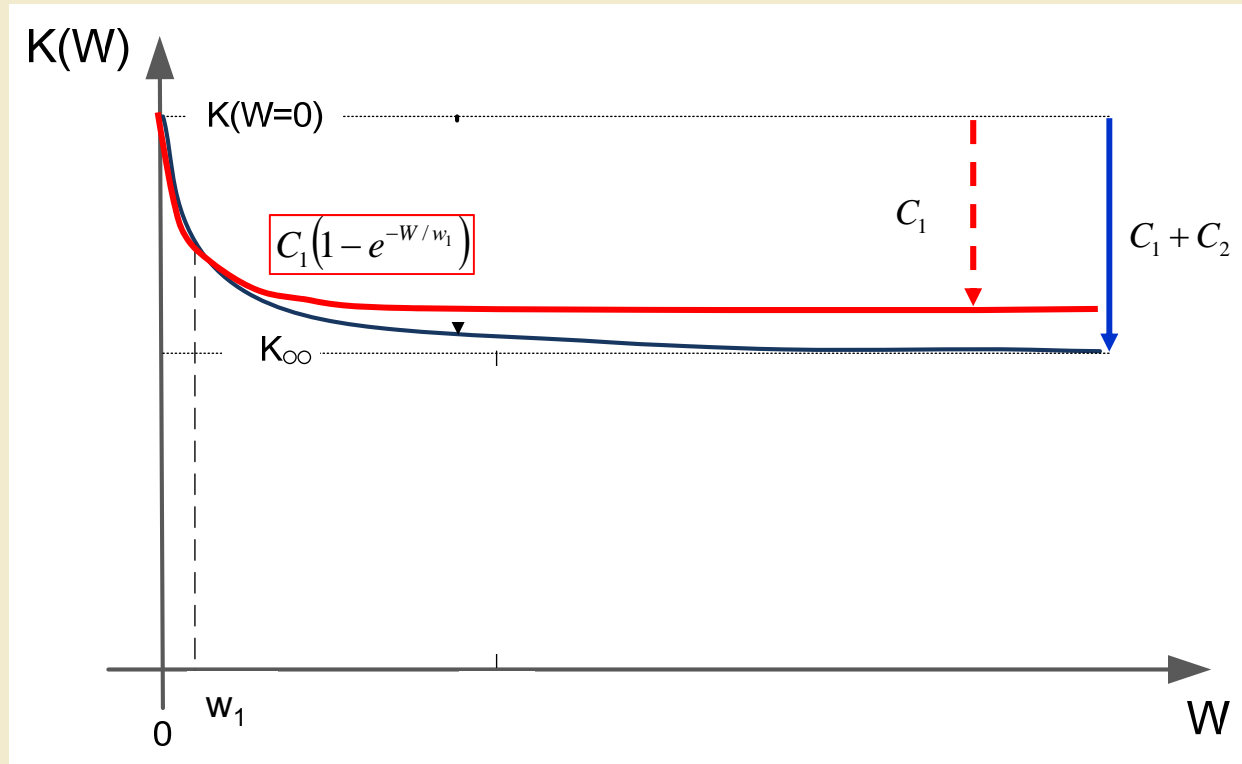

Definition:

$$R_b = \frac{C_1}{C_1 + C_2} 100\% \quad | N = 2$$

The simple model for  $N=2$  is a good approximation of most suspension parts and separates the break-in effect generating the steep decay at the beginning of the aging process from the fatigue causing a much slower decay at large values of accumulated work  $W$ .

$w_1$  describes the amount of work required to complete 63% of the break-in phase.

# 3<sup>rd</sup> Characteristic: Total Fatigue Loss

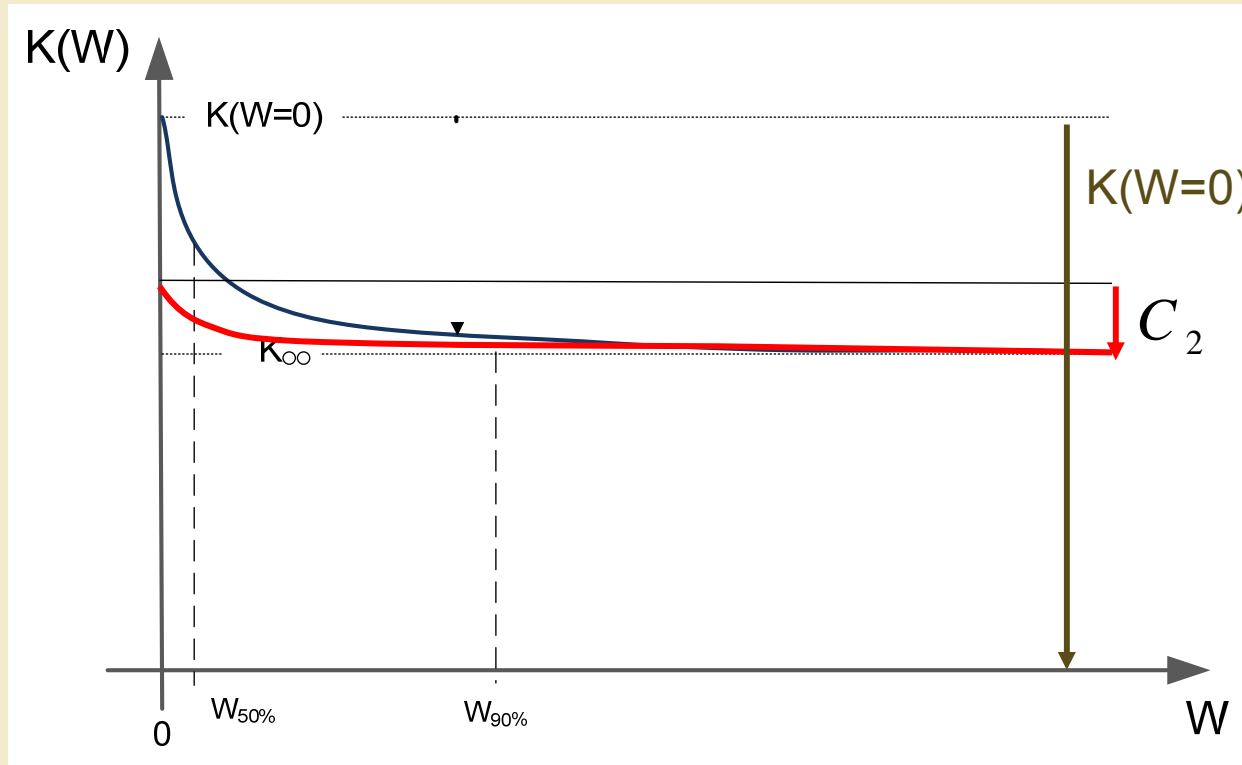

Definition:

$$V_f = \frac{C_2}{K(W=0)} 100\% \quad | N = 2 \quad .$$

describes the percentage of stiffness loss due to fatigue

If the break-in effect is dominant ( $R_b \approx 100\%$ ) and fatigue negligible ( $V_f \approx 0$ ) then we find the relationship  $W_{90\%} \approx 3W_{50\%}$ .

# Important Quality Criteria

for assessing the stability of suspension parts

Criteria	Optimal value	Priority
Minimal fatigue	$V_f = 0\%$	1
Dominant break-in	$R_b = 100\%$ $W_{90\%} \approx 3W_{50\%}$	2
Slow fatigue process	$w_2 > W_a$	3
Total aging ratio	$V_a = 0\%$ <span style="color: red;">at the moment not realistic !</span>	4
Fast break-in process	$w_1 \ll W_a$	5

Nominal value for designing transducers:  $K_{\text{nom}} = K(W = 0) - C_1 \quad | N = 2$

# Influence of the Power Level $P$ on Load-Induced Aging of the Suspension

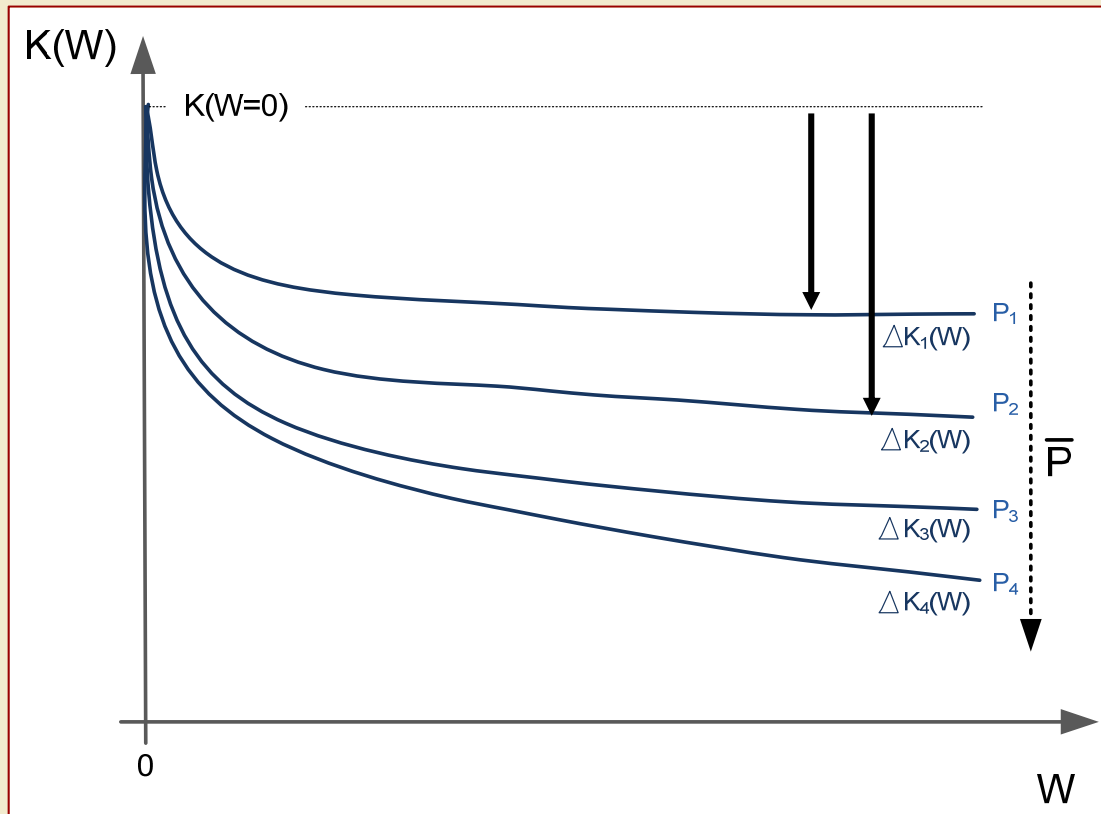

A set of ageing functions  $K(W_j)$  measured at constant mechanical power  $P_j$

Measurement Methodology:

1. Selecting units of the same type with similar properties
2. Applying a constant but different mechanical power  $P_j$  to each unit and measuring the variation of  $K(W_j)$
3. Fitting the constant load model to the  $K(W_j)$  characteristic of each unit

$$\Delta K_j(W_j | P_j) = \sum_{i=1}^N C_{j,i} (1 - e^{-W_k / w_{k,i}}) \quad \left| \begin{array}{l} \bar{P} = P_j = const \\ j = 1, \dots, J \end{array} \right.$$

# Varying Load Model

Objectives:

- To consider the dependency on instantaneous power level
- To predict the stiffness variation for any stimuli

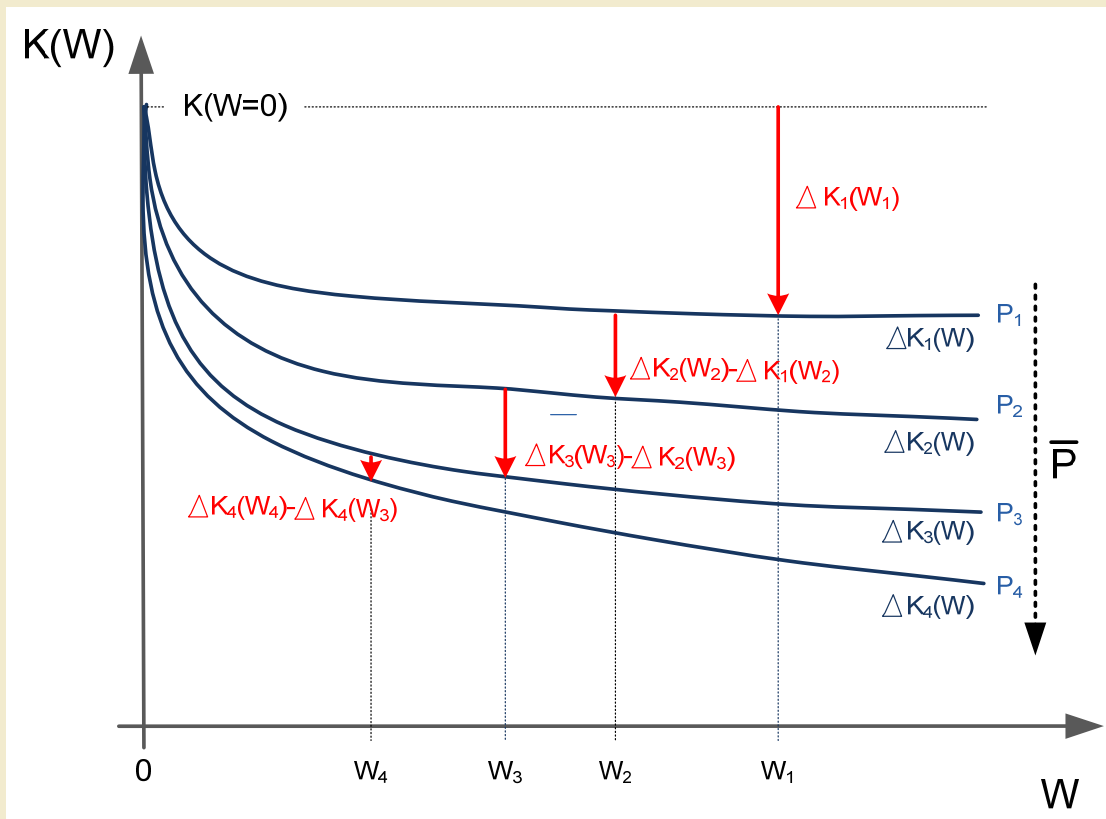

$$\hat{K}(W) = K(W = 0)$$

$$- \sum_{j=2}^J (\Delta K_j(W_j) - \Delta K_{j-1}(W_j)) - \Delta K_1(W_1)$$

using multiple states  $W_j$   
accumulating the power  $P(t)$  above  
the power value  $P_j$  using the  
window function  $g_j(t)$

$$W_j(t_0) = \int_0^{t_0} g_j(t) P(t) dt \quad j = 1, \dots, J$$

$$g_j(t) = \begin{cases} 1 & \text{if } P \geq P_j \\ 0 & \text{otherwise} \end{cases} \quad j = 1, \dots, J$$

# Calculation of Stiffness $K(t)$ for an Arbitrary Power Profile $P(t)$

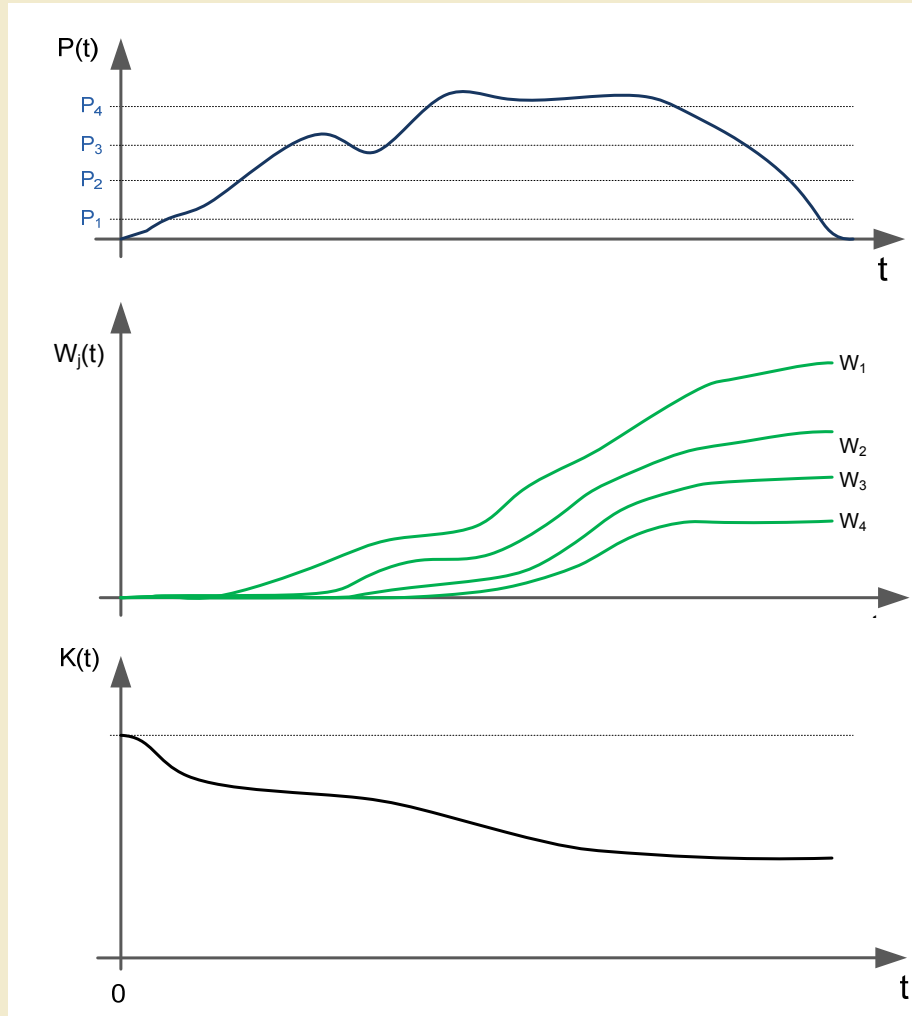

dividing in power levels

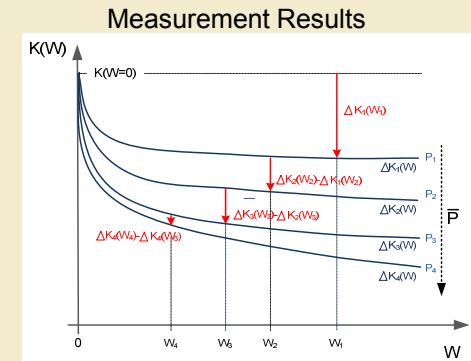

accumulation in the work variables

$$W_j(t_0) = \int_0^{t_0} g_j(t) P(t) dt \quad j = 1, \dots, J$$

$$g_j(t) = \begin{cases} 1 & \text{if } P \geq P_j \\ 0 & \text{otherwise} \end{cases} \quad j = 1, \dots, J$$

$$\hat{K}(W) = K(W = 0)$$

$$- \sum_{j=2}^J (\Delta K_j(W_j) - \Delta K_{j-1}(W_j)) - \Delta K_1(W_1)$$



# Measurement Technology

## Part 1: Suspension Parts



apparent mechanical power

$$P(t) = \left| K(x)x(t) \frac{dx(t)}{dt} \right|$$

displacement sensor

nonlinear system identification

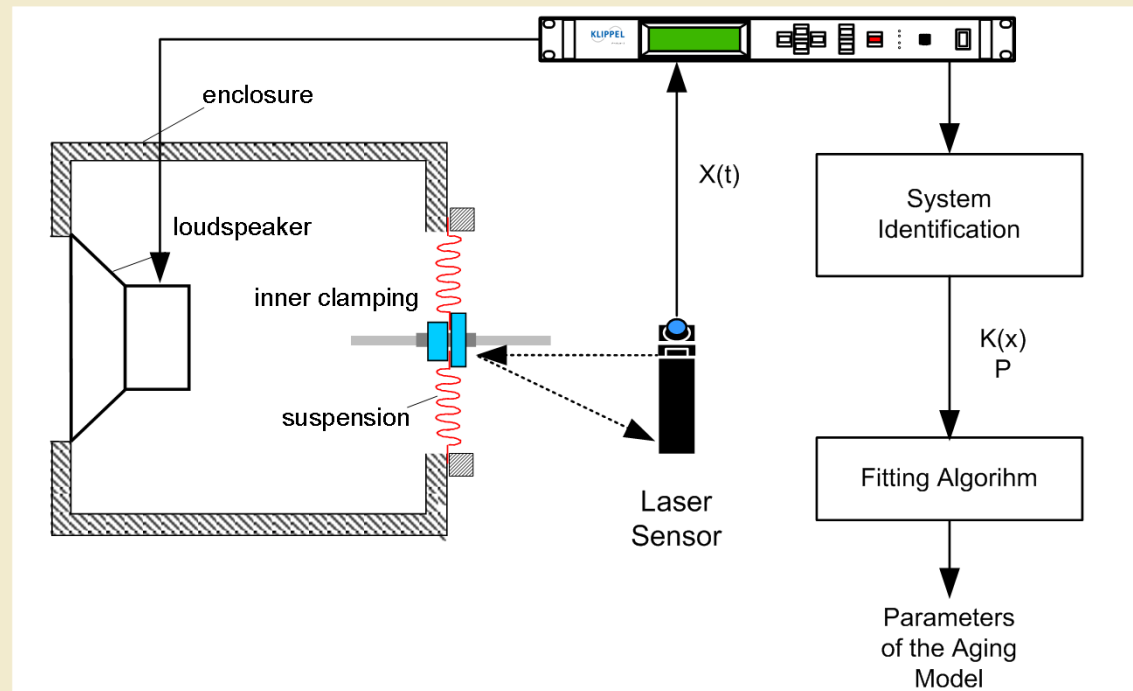

Measurement of spiders, surrounds and passive radiators using a laser sensor and system identification

# Measurement Technology

## Part 2: Electro-dynamical Transducer



Electro-mechanical equivalent circuit of the loudspeaker system

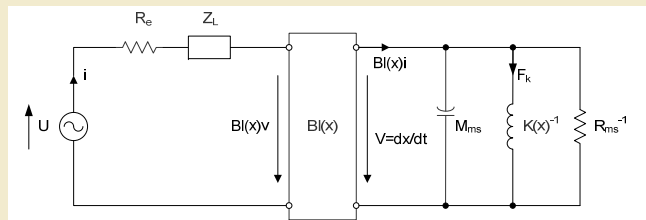

apparent mechanical power

$$\begin{aligned}
 P(t) &= |F_k(x)v(t)| = |K(x)x(t)v(t)| \\
 &= \left| \frac{K(x)}{Bl(x)} x(t)Bl(x)v(t) \right| \\
 &= |i_k(t)u_{emf}(t)|
 \end{aligned}$$

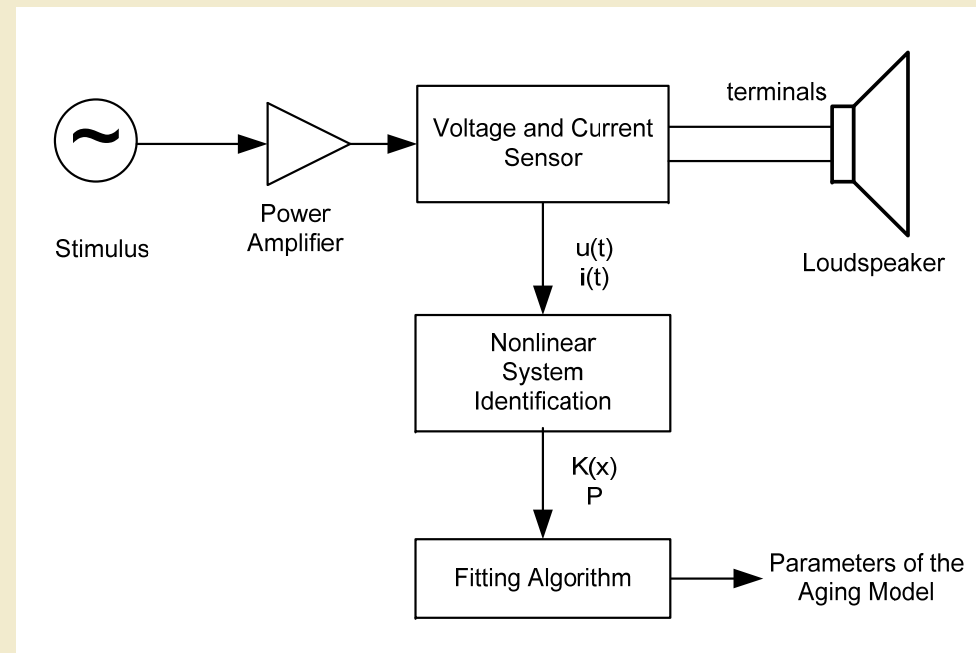

System identification based on voltage and current signals measured at the loudspeaker terminals

# Long-Term Monitoring of Loudspeaker Suspension

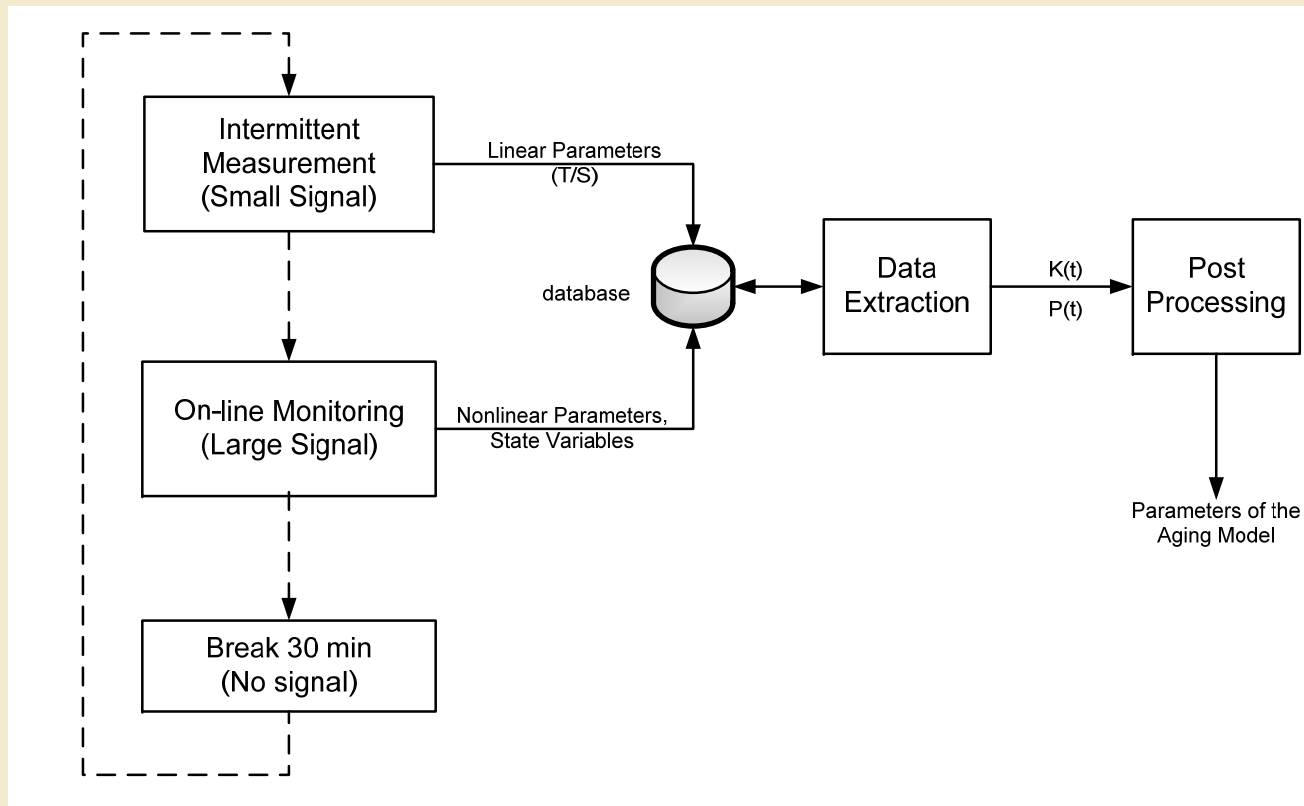

model fitting

$$C = \sum_{m=1}^M (K(W(t_m)) - \hat{K}(W(t_m)))^2 \rightarrow \min.$$

Long-term monitoring by looping a sequence of measurements and post-processing of the collected data.

# Example: Poor Spider

## Suffering from Long-Term Fatigue

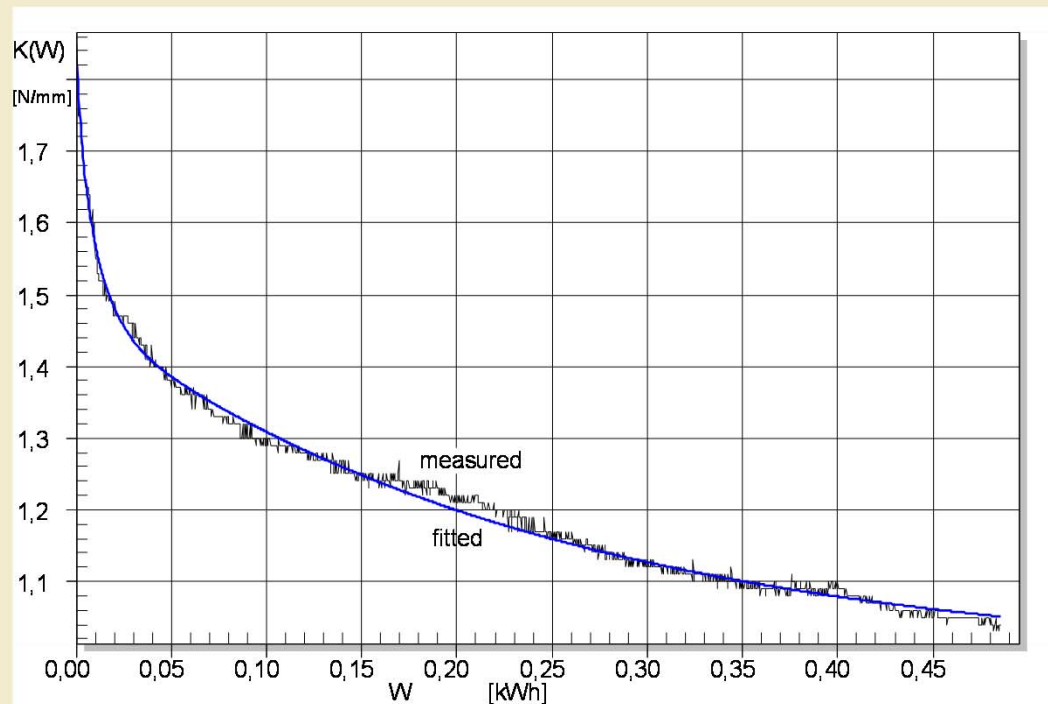

- $V_a \approx 50\%$  → half of the initial stiffness will disappear during the life-cycle of the suspension part.
- $R_b \approx 50\%$  → only half of the changes occur during the relative short break-in process requiring only  $w_1 = 0.02$  kWh.
- $V_f \approx 22\%$  → high fatigue ratio causes a permanent but slow decay of the stiffness
- $W_{90\%} = 0.42$  kWh  $\approx 11W_{50\%}$  → high value of the accumulated work is required to approach 90 percent of the final value  $K_\infty = 0.9$  N/mm (predicted)

# Example: Loudspeaker A

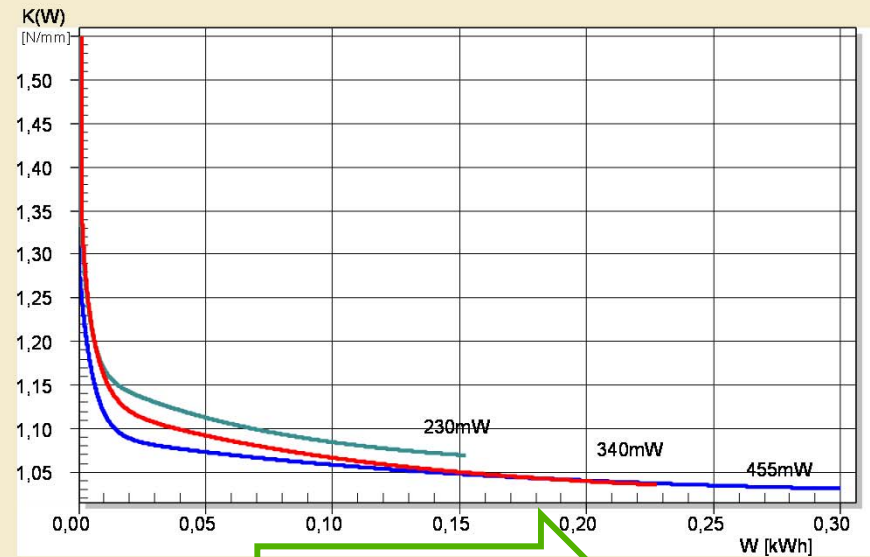
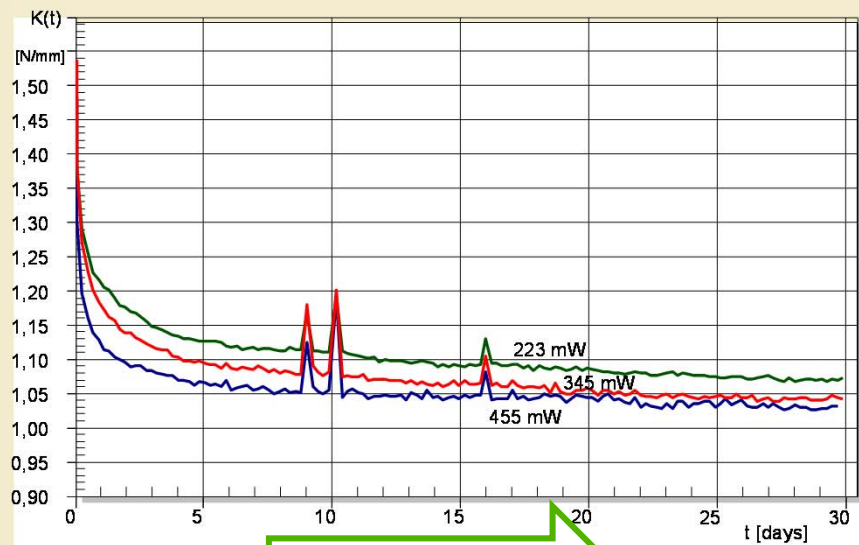

- $V_a \approx 30\%$   $\rightarrow$  small aging ratio
- $R_b \approx 85\%$   $\rightarrow$  most of the variations occur during the dominant break-in process
- $W_{90\%} \approx 0.1$  kWh  $\rightarrow$  small amount of work is required to approach 90% of the final stiffness value.
- Levels are very similar  $\rightarrow$  low dependency on power level

# Influence of Ambient Condition

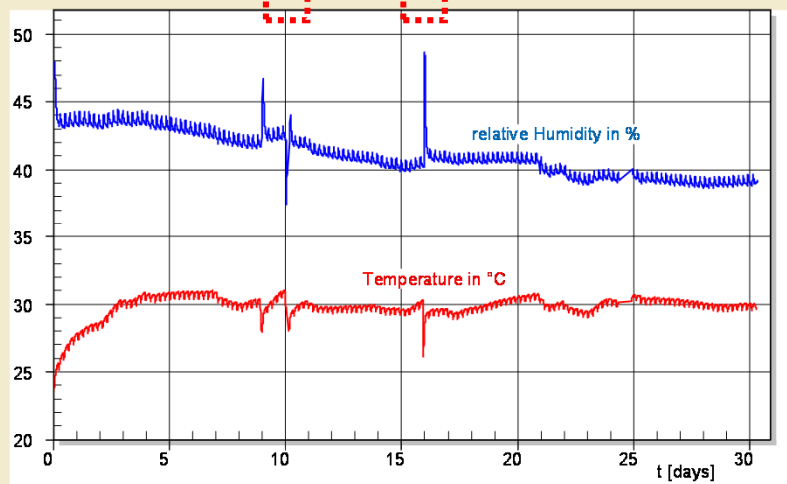
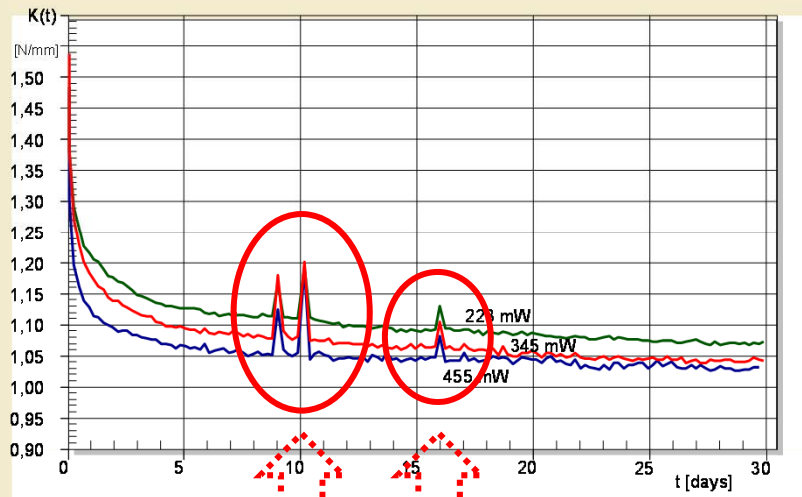

- Ambient temperature and humidity have a strong influence on the stiffness  $K$  of the suspension
- The ambient condition should be constant during the aging test
- Fitting algorithm provided with sufficient data collected at high sampling rate can compensate for short variation

# Conclusions

## Load-induced aging of the suspension material

- can be described by a dosage model using mechanical apparent work  $W$  as state variable
- few aging parameters can be identified from stiffness  $K(t)$  and apparent power  $P(t)$  recorded in long-term tests
- The stiffness variation  $K(t)$  versus time can be predicted for any stimulus using the power profile  $P(t)$
- the model has been verified on a variety of suspension parts and assembled transducers
- The model predicts the final stiffness  $K_{\infty}$  and the intensity and dynamics of the aging process
- Short break-in effect can be easily separated from the long-term fatigue effect
- The stiffness  $K_{\text{nom}}$  found after break-in is a useful nominal characteristic of the suspension part
- A low fatigue loss of stiffness expressed by  $V_f$  reveals the long-term stability of the suspension